

PRODUCT NEWS



02/07/2014

RALLY

Mitsubishi Evo X Grp N

Öhlins Rally application for Mitsubishi Evo X.

Both front and rear are fully pressure balanced, eliminating the risk of cavitation and due to low gas pressure, they keep the internal friction low.

The proven Group N technology has now been updated with new settings based on WRC experience and a WRC developed Dynamic Compression and Dynamic Rebound Control, DCC/DRC, for the front TPX dampers. The Progressive Damping System (PDS) has been updated to increase the performance in jumps and also maintaining temperature stability (gravel). To improve overall traction, performance in jumping and the stability when cutting corners a WRC developed Stroke Dependent Rebound has been added as well. The Twin Piston McPherson strut also has a reinforced outer tube in high strength steel with calibrated bushing seats.

The rear TTX damper has an extruded cylinder tube that creates less damper hysteresis which means improved wheel control and traction on the rear axle. The TTX also has the new updated Progressive Damping System as the front TPX McPherson strut (gravel).

FEATURES

Front TPX

- > Updated setting based on WRC experience and proved winning performance on EVO X
- > WRC developed DCC/DRC (Dynamic Compression/Rebound Control) for improved traction
- > Updated PDS (Progressive Damping System) for increased jumping performance and temperature stability (gravel)
- > WRC developed SDR (Stroke Dependent Rebound) for improved traction, jumping performance and improved stability when cutting corners
- > Reinforced outer tube in high strength steel with calibrated bushing seats

Rear TTX

- > Extruded cylinder tube body with less damper hysteresis for improved wheel control and traction on rear axle
- > Updated PDS (Progressive Damping System) for increased jumping performance and temperature stability (gravel)

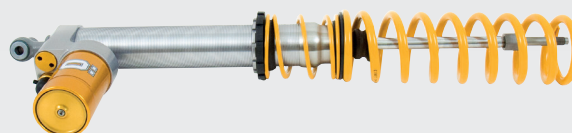

TARMAC - PART NO

Front	MIR 5P54
Right Rear	MIR 4P54
Left Rear	MIR 3P54

GRAVEL - PART NO

Front	MIR 5N50
Right Rear	MIR 4N50
Left Rear	MIR 3N50



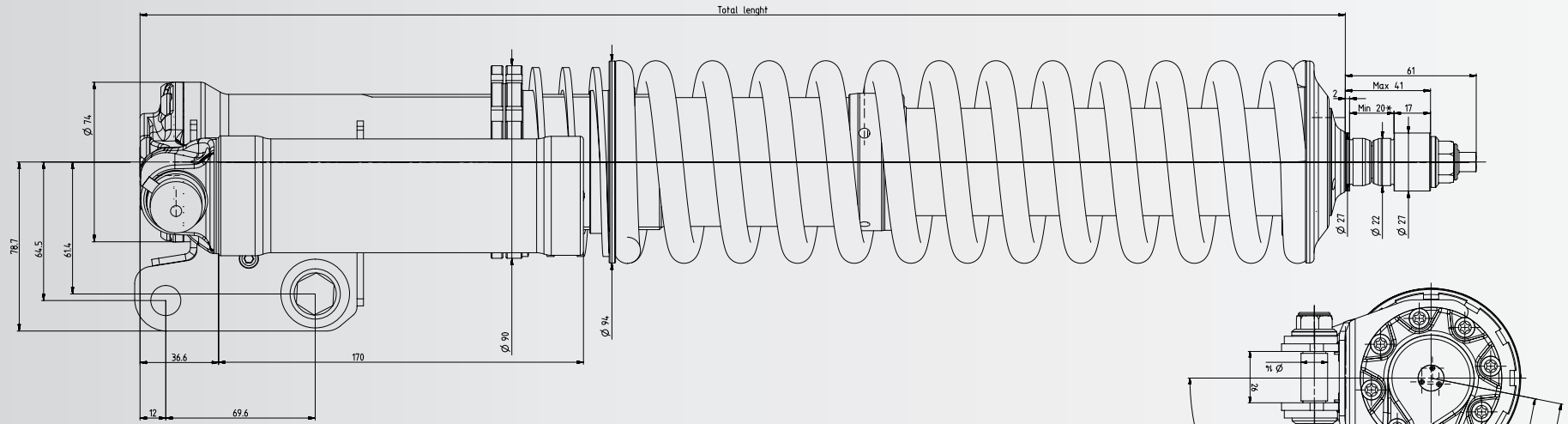

182	544	Tarmac Front Group N	MIR5P54
189	561	Gravel Front Group N	MIR5N50
Stroke	Total length	Description	Part number

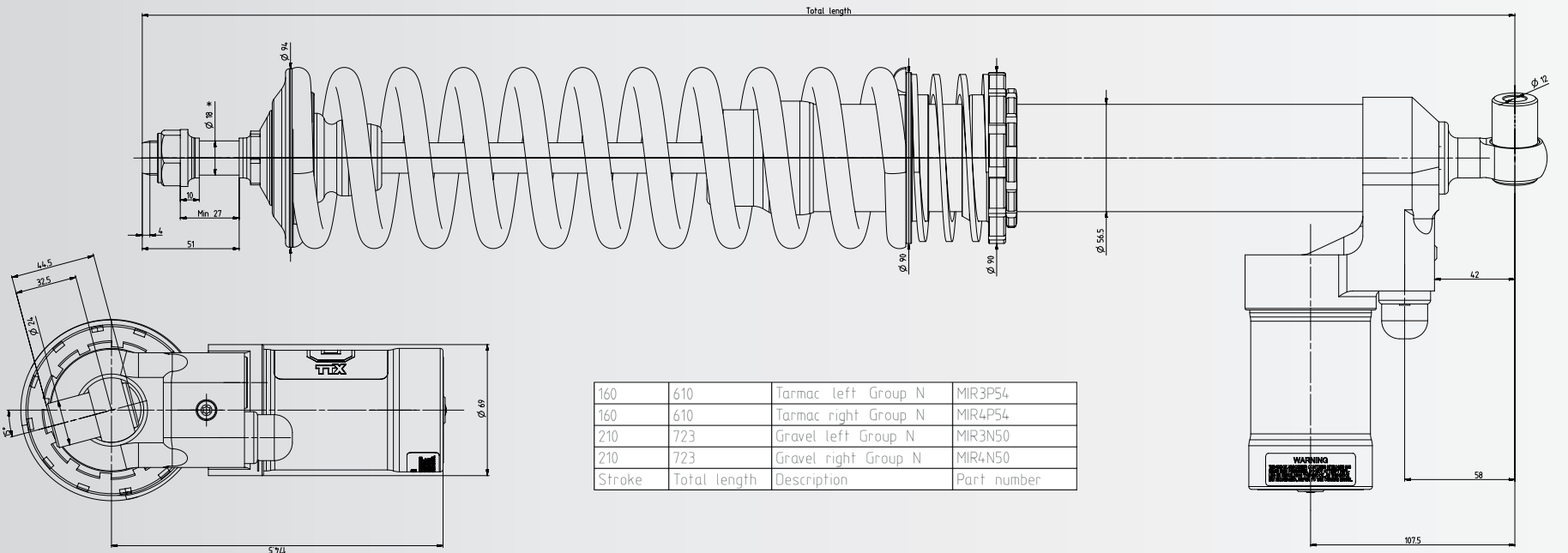
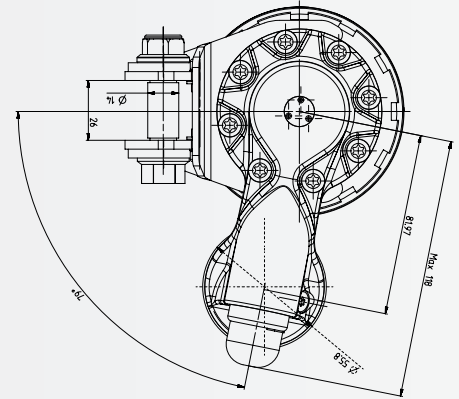

160	610	Tarmac left Group N	MIR3P54
160	610	Tarmac right Group N	MIR4P54
210	723	Gravel left Group N	MIR3N50
210	723	Gravel right Group N	MIR4N50
Stroke	Total length	Description	Part number

